























The affordable system with high performance allows threading and / or circlip grooving in high precision. The polygonal connection of insert and milling body improves the efficiency and precision of the process significantly:

- Longer tool life
- Higher machining volume
- Higher feed rates
- Shorter processing times
- High stability
- High security at interrupted cutting

## Symbols

	Type designation		Blank inserts must be equipped with a clearance angle!
	Tool shank without clamping surface		Inserts without profile, ready for use with clearance angle.
	Tool shank with Weldon clamping surface		Inserts for guard ring slots
	Solid carbide shaft without clamping surface		Inserts for O-ring slots
	Solid carbide shaft with Weldon clamping surface		DIN standard
	Tool with Conical tool shank		Inserts with chamfered edges
	Tool with tightening thread		Inserts with chipbreakers from 5 mm cutting width
	Cutter with cross groove		For chamfering and deburring
	Smallest necessary bore-diameter		Number of inserts (Polygon Cutter)
	Maximum cutting depth		Thread depth max.
	Internal coolant supply		Edge radius
			Full radius

## Formula for Tool Lengths

$$L_{WKZ} = L_{GK} + L_1 + L_{P1} (+L_{P2})$$

# Slot Milling

- Insert holder see page 104-106
- Cutting data see page 189

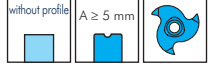
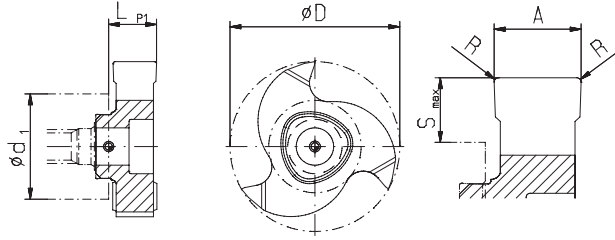

Type	A mm	A inch	D mm	Rake Angle	R mm	LP1 mm	LP2 mm	S <sub>max</sub> mm	Number of teeth	Order No. TINAMATIC	
P12	P1210	0,74	.029	9,6	6°	0,1	3,25	0,1	1,2	3	171915
	P1210	0,84	.033	9,6	6°	0,1	3,25	0,1	1,2	3	171916
	P1210	1	.039	9,6	6°	0,1	3,25	0,1	1,2	3	171917
	P1210	1,2	.047	9,6	6°	0,1	3,25	0,1	1,2	3	171918
	P1210	1,4	.055	9,6	6°	0,1	3,25	0,1	1,2	3	171919
	P1210	1,5	.059	9,6	6°	0,1	3,25	0,1	1,2	3	171920
	P1210	1,575	.062	9,6	6°	0,1	3,25	0,1	1,2	3	173937
	P1210	1,7	.067	9,6	6°	0,1	3,25	0,1	1,2	3	171921
	P1210	2	.079	9,6	6°	0,1	3,75	-	1,2	3	171922
	P1210	2,5	.098	9,6	6°	0,1	3,75	-	1,2	3	171923
	P1212	1,5	.059	11,7	6°	0,1	3,4	-	2,25	3	171862
	P1212	2	.079	11,7	6°	0,15	3,4	-	2,25	3	171863
	P1212	2,5	.098	11,7	6°	0,15	3,4	-	2,25	3	171865
	P1212	3	.118	11,7	6°	0,15	3,55	-	2,25	3	171866
P1212	3,175	.125	11,7	6°	0,15	3,75	-	2,25	3	173938	
P16	P1616	3,5	.138	16	0°	0,15	4,15	-	3,5	3	142531
	P1616	3,5	.138	16	8°	0,15	4,15	-	3,5	3	142486
	P1616	3,5	.138	16	12°	0,15	4,15	-	3,5	3	142526
	P1616	5	.197	16	0°	0,15	5,65	-	3,5	3	142511
	P1616	5	.197	16	8°	0,15	5,65	-	3,5	3	142541
	P1616	5	.197	16	12°	0,15	5,65	-	3,5	3	142457
P25	P2525	4	.157	25	0°	0,15	4,65	-	5,7	3	142556
	P2525	4	.157	25	8°	0,15	4,65	-	5,7	3	142546
	P2525	4	.157	25	12°	0,15	4,65	-	5,7	3	142579
	P2525	5	.197	25	8°	0,15	5,75	-	5,7	3	142538
	P2525	6	.236	25	8°	0,15	6,90	-	5,7	3	160907 <b>NEW</b>
	P2525	6,35	.250	25	8°	0,15	7,15	-	5,7	3	173939
	P2525	6,5	.256	25	0°	0,15	7,15	-	5,7	3	142582
	P2525	6,5	.256	25	8°	0,15	7,15	-	5,7	3	142610
	P2525	6,5	.256	25	12°	0,15	7,15	-	5,7	3	142574
	P2525	8	.315	25	0°	0,15	8,65	-	5,7	3	142558
	P2525	8	.315	25	8°	0,15	8,65	-	5,7	3	142578
P2525	8	.315	25	12°	0,15	8,65	-	5,7	3	142588	

## Slot Milling, Straight Toothed

- Insert holder see page 104-106
- Cutting data see page 189

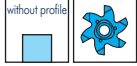
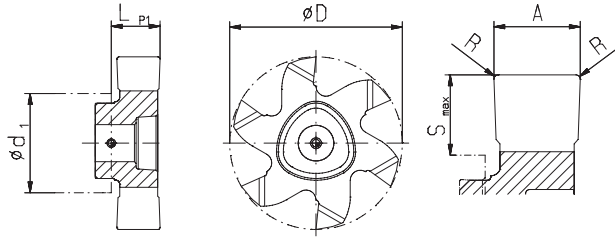

Type	A mm	A inch	D mm	Rake Angle	R mm	LP1 mm	S <sub>max.</sub> mm	Number of teeth	Order No. TINAMATIC	
P16	P1616	3,0	.118	16,0	6°	0,15	3,53	3,5	6	142494
	P1616	3,175	.125	16,0	6°	0,05	3,74	3,5	6	173929
	P1616	4,0	.157	16,0	6°	0,15	4,65	3,5	6	142565
	P1616	5,0	.197	16,0	6°	0,15	5,65	3,5	6	142586
	P1618	1,2	.047	17,7	6°	0,1	4,0	4,0	6	171937
	P1618	1,4	.055	17,7	6°	0,1	4,0	4,0	6	171938
	P1618	1,5	.059	17,7	6°	0,1	3,9	4,0	6	171939
	P1618	1,57	.062	17,7	6°	0,1	3,9	4,0	6	173928
	P1618	1,7	.067	17,7	6°	0,1	4,0	4,0	6	171940
	P1618	2,0	.079	17,7	6°	0,1	3,9	4,0	6	171941
	P1618	2,39	.094	17,7	6°	0,15	4,0	4,0	6	171942
	P1618	2,5	.098	17,7	6°	0,15	3,9	4,0	6	171943
P20	P2020	3,0	.118	20,0	6°	0,15	3,65	4,2	6	168673
	P2020	4,0	.157	20,0	6°	0,15	4,65	4,2	6	168674
	P2020	5,0	.197	20,0	6°	0,15	5,65	4,2	6	142655
	P2022	1,4	.055	21,7	6°	0,1	5,0	5,0	6	171956
	P2022	1,5	.059	21,7	6°	0,1	5,0	5,0	6	171957
	P2022	1,57	.062	21,7	6°	0,1	5,0	5,0	6	173930
	P2022	1,7	.067	21,7	6°	0,1	5,0	5,0	6	171958
	P2022	2,0	.079	21,7	6°	0,1	5,0	5,0	6	171959
	P2022	2,39	.094	21,7	6°	0,15	5,0	5,0	6	171960
	P2022	2,5	.098	21,7	6°	0,15	5,0	5,0	6	171961
	P2022	3,0	.118	21,7	6°	0,15	5,0	5,0	6	171962
	P2022	3,175	.125	21,7	6°	0,15	5,0	5,0	6	171963
	P2022	4,0	.157	21,7	6°	0,15	5,0	5,0	6	182370 NEW
	P2022	5,0	.197	21,7	6°	0,15	6,0	5,0	6	187947 NEW
P25	P2526	3,0	.118	26,0	6°	0,15	3,65	6,2	6	142601
	P2526	3,175	.125	26,0	6°	0,15	3,7	6,2	6	173932
	P2526	4,0	.157	26,0	6°	0,15	4,65	6,2	6	142677
	P2526	5,0	.197	26,0	6°	0,15	6,9	6,2	6	142589
	P2526	6,0	.236	26,0	6°	0,15	7,15	6,2	6	162646 NEW
	P2526	6,35	.250	26,0	6°	0,15	6,95	6,2	6	173931
	P2526	6,5	.256	26,0	6°	0,15	7,15	6,2	6	142618
	P2528	1,5	.059	27,7	6°	0,1	4,9	6,8	6	171981
	P2528	2,0	.079	27,7	6°	0,1	4,9	6,8	6	171982
	P2528	2,39	.094	27,7	6°	0,15	4,9	6,8	6	171983
	P2528	2,5	.098	27,7	6°	0,15	4,9	6,8	6	171984
	P2528	3,0	.118	27,7	6°	0,15	4,9	6,8	6	171985
	P2528	3,175	.125	27,7	6°	0,15	5,0	6,8	6	171986

## Slot Milling, Cross Toothed

- Insert holder see page 104-106
- Cutting data see page 189

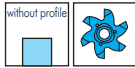
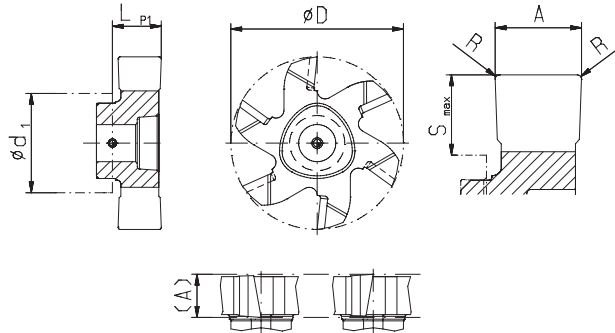

Type	A mm	A inch	D mm	Rake Angle	R mm	LP1 mm	Smax. mm	Number of teeth	Order No. TINAMATIC	
P16	P1616	5,0	.197	16,0	6°	0,15	5,65	3,5	6	171699
	P2020	5,0	.197	20,0	6°	0,15	5,65	4,2	6	171700
P20	P2022	4,0	.157	21,7	6°	0,15	5,0	5,0	6	163659
	P2022	5,0	.197	21,7	6°	0,15	6,0	5,0	6	187948 <b>NEW</b>
P25	P2526	5,0	.197	26,0	6°	0,15	6,9	6,2	6	171701
	P2526	6,5	.256	26,0	6°	0,15	7,15	6,2	6	171702
	P2528	4,0	.157	27,7	6°	0,15	5,9	6,8	6	177186
	P2528	5,0	.197	27,7	6°	0,15	5,9	6,8	6	177187

**i** Further slotting widths on request

## Circlip Grooves

- With chamfered edge
- Insert holder see page 104-106
- Cutting data see page 189

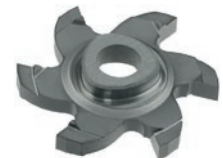
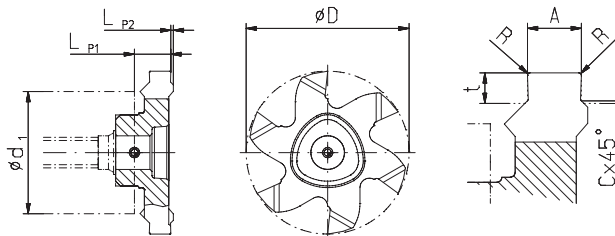

Type	DIN Width H13	D mm	A <sub>0,03</sub> mm	t mm	Cx45° mm	R mm	LP1 mm	LP2 mm	Number of teeth	Order No. TINAMATIC	
P16	P1616	1,10	16	1,18	0,50	0,10	0,05	3,15	0,675	6	142423
	P1616	1,30	16	1,38	0,85	0,15	0,05	3,15	0,675	6	142528
	P1616	1,60	16	1,68	1,00	0,15	0,1	3,15	0,675	6	142561
	P1616	1,85	16	1,93	1,25	0,20	0,1	3,15	0,675	6	142562
P20	P2020	1,10	20	1,18	0,50	0,10	0,05	3,15	0,675	6	168675
	P2020	1,30	20	1,38	0,85	0,15	0,05	3,15	0,675	6	168676
	P2020	1,60	20	1,68	1,00	0,15	0,1	3,15	0,675	6	168677
	P2020	1,85	20	1,93	1,25	0,20	0,1	3,15	0,675	6	168678
	P2022	1,60	21,7	1,68	1,00	0,15	0,1	4,7	0,45	6	171968
	P2022	1,85	21,7	1,93	1,25	0,20	0,1	4,7	0,45	6	171969
	P2022	2,15	21,7	2,23	1,50	0,20	0,1	4,7	0,45	6	171970
	P2022	2,65	21,7	2,73	1,75	0,20	0,2	4,8	0,35	6	171971
P25	P2526	1,30	26	1,38	0,85	0,15	0,05	3,4	0,425	6	142646
	P2526	1,60	26	1,68	1,00	0,15	0,1	3,4	0,425	6	142660
	P2526	1,85	26	1,93	1,25	0,20	0,1	3,4	0,425	6	142607
	P2526	2,15	26	2,23	1,50	0,20	0,1	3,4	0,425	6	142591
	P2526	2,65	26	2,73	1,75	0,20	0,2	4,25	0,575	6	142597
	P2526	3,15	26	3,23	1,75	0,20	0,2	4,25	0,575	6	142661
	P2526	4,15	26	4,23	2,00	0,20	0,2	6,415	0,560	6	142622
	P2526	4,15	26	4,23	2,50	0,20	0,2	6,415	0,560	6	160893 <b>NEW</b>

## Circlip Grooves

- Without chamfered edge
- Insert holder see page 104-106
- Cutting data see page 189

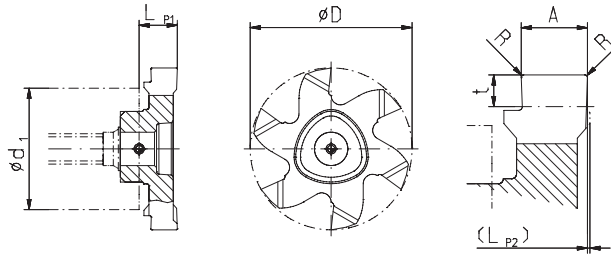

Type	DIN Width <sup>H13</sup>	D mm	A <sub>±0,03</sub> mm	t mm	R mm	LP1 mm	LP2 mm	Number of teeth	Order No TINAMATIC	
P12	P1210	0,90	9,6	0,98	1,20	0,05	3,25	0,1	3	172125
	P1212	1,10	11,7	1,18	0,90	0,05	3,55	–	3	171868
	P1212	1,30	11,7	1,38	1,10	0,05	3,55	–	3	171869
	P1212	1,60	11,7	1,68	1,00	0,1	3,55	–	3	171870
P16	P1616	1,10	16,0	1,18	0,90	0,05	3,45	–	6	142548
	P1616	1,30	16,0	1,38	1,10	0,05	3,45	–	6	142509
	P1616	1,60	16,0	1,68	1,25	0,1	3,45	–	6	142533
	P1616	1,85	16,0	1,93	1,25	0,1	3,45	–	6	142536
	P1618	1,10	17,7	1,18	0,90	0,05	4,0	–	6	171945
	P1618	1,30	17,7	1,38	1,10	0,05	4,0	–	6	171946
	P1618	1,60	17,7	1,68	1,25	0,1	3,9	–	6	171947
P20	P1618	1,85	17,7	1,93	1,25	0,1	4,0	–	6	171948
	P2020	1,10	20,0	1,18	0,90	0,05	3,65	–	6	168679
	P2020	1,30	20,0	1,38	1,10	0,05	3,65	–	6	168680
	P2020	1,60	20,0	1,68	1,25	0,1	3,65	–	6	168681
	P2020	1,85	20,0	1,93	1,25	0,1	3,65	–	6	168682
	P2022	1,60	21,7	1,68	1,25	0,1	5,0	–	6	171964
	P2022	1,85	21,7	1,93	1,25	0,1	5,0	–	6	171965
P25	P2022	2,15	21,7	2,23	1,75	0,1	5,0	–	6	171966
	P2022	2,65	21,7	2,73	1,75	0,2	5,0	–	6	171967
	P2526	1,30	26,0	1,38	1,10	0,05	3,65	–	6	142598
	P2526	1,60	26,0	1,68	1,25	0,1	3,65	–	6	142653
	P2526	1,85	26,0	1,93	1,25	0,1	3,65	–	6	142616
	P2526	2,15	26,0	2,23	1,75	0,1	3,65	–	6	142637
	P2526	2,65	26,0	2,73	1,75	0,2	3,65	–	6	142662
P25	P2526	3,15	26,0	3,23	2,20	0,2	4,55	–	6	142643
	P2526	4,15	26,0	4,23	2,50	0,2	6,80	–	6	160906 <b>NEW</b>

## Circular Milling Tools with Polygonal Insert Seat

- Inserts see page 100-103
- Cutting data see page 189

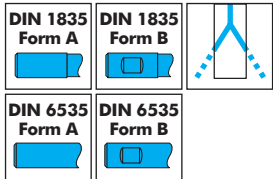
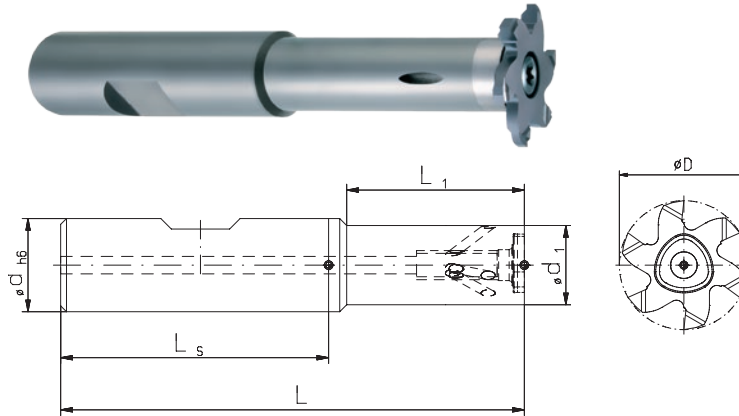

Type	Order No.	Form	Bore Ø min. recommended	dh6 mm	d1 mm	Dmax. mm	Smax. (D-d1)/2 mm	L mm	L1 mm	Shaft	Spare part No.	
											Screw-driver	Screw
P12	123619	B	12	12	7,0	11,7	2,35	67,5	20	Steel	T8 IP 111656	M2,5x7 107596
	100228	B	12	12	7,0	11,7	2,35	67,5	20	Carbide		
	171778	A	12	12	7,0	11,7	2,35	67,5	20	Carbide		
	171780	B	12	12	7,0	11,7	2,35	80	30	Carbide		
	171781	A	12	12	7,0	11,7	2,35	80	30	Carbide		
	171783	B	12	12	7,0	11,7	2,35	100	40	Carbide		
P16	123573	B	18	12	9,0	17,7	4,35	67,4	21	Steel	T8 IP 111656	M3x12 143158
	123577	B	18	12	9,0	17,7	4,35	67,4	21	Carbide		
	171787	A	18	12	9,0	17,7	4,35	67,4	21	Carbide		
	123580	B	18	12	9,0	17,7	4,35	82,4	36	Carbide		
	171789	A	18	12	9,0	17,7	4,35	82,4	36	Carbide		
	123584	A	18	12	9,0	17,7	4,35	100	30	Carbide		
	123588	A	18	12	12,0	17,7	2,85	82,4	-	Carbide		
123590	A	18	12	12,0	17,7	2,85	122,5	-	Carbide			
P20	123615	B	22	16	11,5	21,7	5,1	80	30	Steel	T15 IP 111671	M4x13 107597
	123616	B	22	16	11,5	21,7	5,1	80	30	Carbide		
	171794	A	22	16	11,5	21,7	5,1	80	30	Carbide		
	123617	B	22	16	11,5	21,7	5,1	100	50	Carbide		
	171796	A	22	16	11,5	21,7	5,1	100	50	Carbide		
	174314	A	22	16	15,5	21,7	3,1	105,5	21	Carbide		
P25	123592	B	28	16	13,6	27,7	7,05	79,6	30,5	Steel	T20 IP 111594	M5x13,5 107529
	123598	B	28	16	13,6	27,7	7,05	79,6	30,5	Carbide		
	171855	A	28	16	13,6	27,7	7,05	79,6	30,5	Carbide		
	123600	B	28	16	13,6	27,7	7,05	94,6	45,5	Carbide		
	171857	A	28	16	13,6	27,7	7,05	94,6	45,5	Carbide		
	123603	B	28	16	13,6	27,7	7,05	109,6	60,5	Carbide		
	171859	A	28	16	13,6	27,7	7,05	109,6	60,5	Carbide		
	123609	A	28	16	15,5	27,7	6,1	105	21,5	Carbide		
	123611	A	28	16	15,5	27,7	6,1	149,5	21,5	Carbide		
	123613	A	28	20	15,5	27,7	6,1	178,5	21,5	Carbide		

Screw torques max.

107596	T08 IP	1,0 Nm
143158	T08 IP	1,1 Nm
107597	T15 IP	3,8 Nm
107529	T20 IP	5,5 Nm

## Circular Milling Tools for Driven Toolholders

- Inserts see page 100-103
- Cutting data see page 189

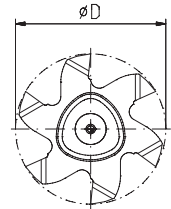
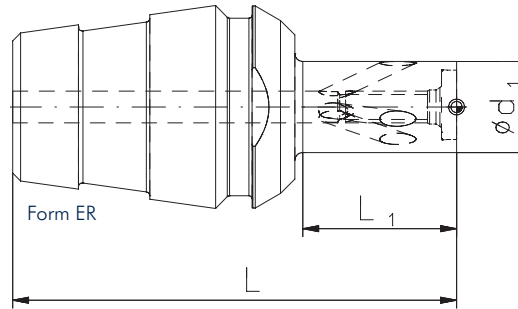
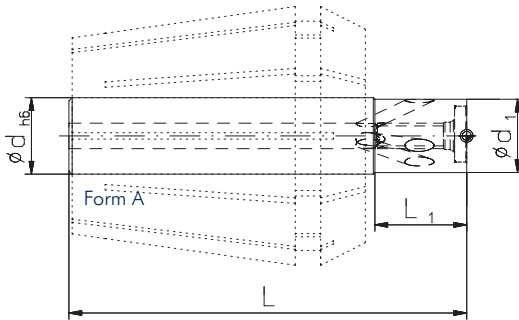
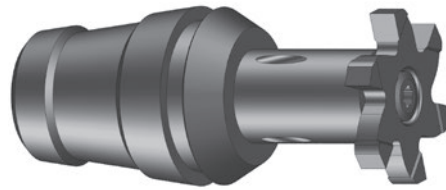

Type	Order No.	Form	Bore $\varnothing$ min. recommended	dh6 mm	d1 mm	Dmax. mm	S <sub>max.</sub> (D-d1)/2 mm	L mm	L1 mm	Shaft	Spare part No.	
											Screw-driver	Screw
P12	177170	A	12	10	7,0	11,7	2,35	54	8	Steel	T8 IP 111656	M2,5x7 107596
	177172	ER 16	12		7,0	11,7	2,35	37,5	8	Steel		
	177173	ER 20	12		7,0	11,7	2,35	47	13	Steel		
P16	177174	A	18	10	9,0	17,7	4,35	60	11	Steel	T8 IP 111656	M3x12 143158
	177176	ER 16	18		9,0	17,7	4,35	41,4	11	Steel		
	177177	ER 20	18		9,0	17,7	4,35	51	16	Steel		
P20	177178	A	22	12	11,5	21,7	5,1	62,4	14,4	Steel	T15 IP 111671	M4x13 107597
	177180	ER 20	22		11,5	21,7	5,1	49,5	14,5	Steel		
	177181	ER 25	22		11,5	21,7	5,1	56	19,4	Steel		
P25	177182	A	28	16	13,6	27,7	7,05	69,6	20,4	Steel	T20 IP 111594	M5x13,5 107529
	177184	ER 25	28		13,6	27,7	7,05	56	19,4	Steel		
	177185	ER 32	28		13,6	27,7	7,05	73	30,4	Steel		

Screw torques max.

107596	T8 IP	1,0 Nm
143158	T8 IP	1,1 Nm
107597	T15 IP	3,8 Nm
107529	T20 IP	5,5 Nm

## Changing Inserts

Clamp cutter before changing insert. Loosen insert screw. Remove used insert and clean the insert pocket before clamping new insert. Please use the appropriate TIP hex key for the tightening of the inserts and consider the screw tightening torques in the tables.

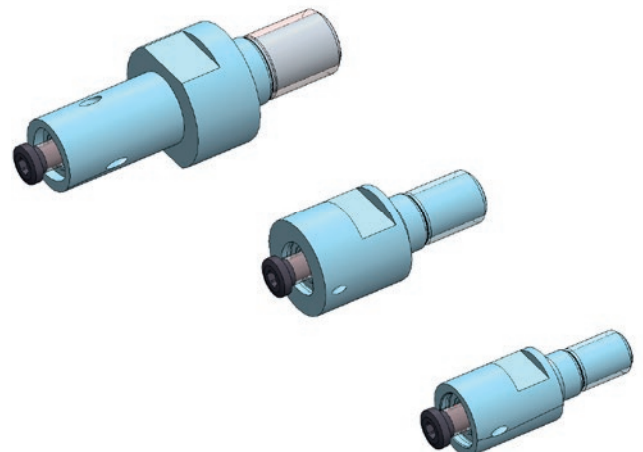



## Circular Milling Tools with Polygonal Insert Seat

- Inserts see page 100-103
- Cutting data see page 189

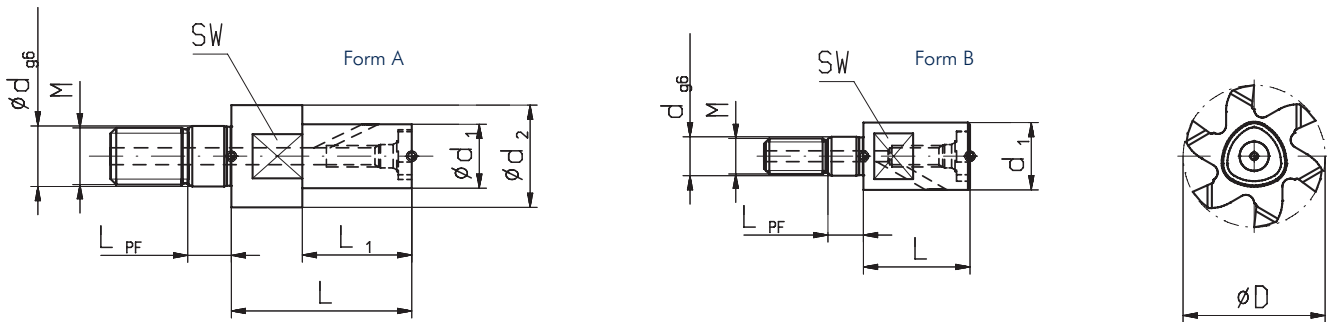

Please adapt cutting data to overhangs length

Type	Order No.	Form	Bore $\varnothing$ min. recommended	$d_1$ mm	$d_2$ mm	$D_{max.}$ mm	$S_{max.}$ $(D-d_1)/2$ mm	L mm	$L_1$ mm	M	$d_{g6}$ mm	L <sub>PF</sub> mm	Spare part No.	
													Screwdriver	Screw
P12***	177676	B	12	9,5	–	11,7	1,1	13,5	–	M5	5,5	5,0	111656	107596
P16	123586	A	18	9,0	14,4	17,7	4,35	29,5	19,5	M8	8,5	5,5	111656	143158
P16**	177683	B	18	9,5	–	17,7	4,1	18,5	–	M5	5,5	5,0	111656	143158
P16***	177698	B	18	11,0	–	17,7	3,35	18,5	–	M6	6,5	5,0	111656	143158
P20	123618	A	22	11,5	18,0	21,7	5,1	35,0	25,0	M10	10,5	5,5	111671	107597
P20**	177734	B	22	11,5	–	21,7	5,1	20,5	–	M6	6,5	5,0	111671	107597
P20***	177735	B	22	13,5	–	21,7	4,1	20,5	–	M8	8,5	5,5	111671	107597
P25	123605	A	27	13,6	22,5	27,7	7,05	42,5	29,5	M12	12,5	5,5	111594	107529
P25**	177747	B	27	13,6	–	27,7	7,05	22,6	–	M8	8,5	5,5	111594	107529
P25***	177767	B	27	18,0	–	27,7	4,85	22,6	–	M10	10,5	5,5	111594	107529

- \*\* Slim design for thread milling
- \*\*\* Reinforced design

Screw torques max.

107596	T8 IP	1,0 Nm
143158	T8 IP	1,1 Nm
107597	T15 IP	3,8 Nm
107529	T20 IP	5,5 Nm

## Assembling Instructions

- Recommended tightening torque for screw-in circular milling body

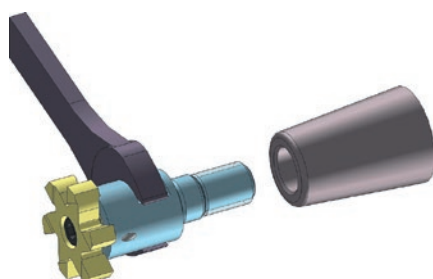

Thread size (M)	Wrench size mm	Tightening torque Nm
M5	7	8
M6	9	10
M8	11	25
M10	15	40
M12	19	60

# Cutting Data Reference Values

	Material	Strength	PolyREAM		SolidCUT			
			TINAMATIC	Measurement at Ø 0,2 mm	TINAMATIC	Ø 2,4 - 3,15	Ø 4	Ø 4,8 - 16
			Vc (m/min.)	fz mm	Vc (m/min.)	fz mm	fz mm	fz mm
<b>A</b>	1.1 General construction steel	< 800 N/mm <sup>2</sup>	180-200	0,20-0,25	80-250	0,03-0,04	0,03-0,06	0,05-0,15
	1.2 Free cutting steel	< 800 N/mm <sup>2</sup>	180-200	0,20-0,25	80-250	0,03-0,04	0,03-0,06	0,05-0,15
	1.3 Unalloyed cementation steel	< 800 N/mm <sup>2</sup>	180-200	0,20-0,25	80-250	0,03-0,04	0,03-0,06	0,05-0,15
	1.4 Alloyed cementation steels	< 1000 N/mm <sup>2</sup>	160-180	0,15-0,20	60-120	0,01-0,02	0,01-0,03	0,05-0,10
	1.5 Unalloyed heat-treatable steel	< 850 N/mm <sup>2</sup>	180-200	0,20-0,25	60-120	0,01-0,02	0,01-0,03	0,05-0,10
	1.6 Unalloyed heat-treatable steel	< 1000 N/mm <sup>2</sup>	160-180	0,15-0,20	60-120	0,01-0,02	0,01-0,03	0,05-0,10
	1.7 Alloyed heat-treatable steel	< 800 N/mm <sup>2</sup>	180-200	0,20-0,25	80-200	0,03-0,04	0,03-0,06	0,05-0,10
	1.8 Alloyed heat-treatable steel	< 1300 N/mm <sup>2</sup>	140-160	0,12-0,18	40-100	0,01-0,02	0,03-0,05	0,04-0,06
	1.9 Cast Steel	< 850 N/mm <sup>2</sup>	180-200	0,20-0,25	60-120	0,01-0,02	0,04-0,07	0,05-0,10
	1.10 Nitriding steel	< 1000 N/mm <sup>2</sup>	160-180	0,15-0,20	60-120	0,01-0,02	0,04-0,07	0,05-0,10
	1.11 Nitriding steel	< 1200 N/mm <sup>2</sup>	150-170	0,15-0,20	40-100	0,01-0,02	0,03-0,05	0,04-0,06
	1.12 Ball bearing steel	< 1200 N/mm <sup>2</sup>	150-170	0,15-0,20	40-100	0,01-0,02	0,03-0,05	0,04-0,06
	1.13 Spring steel	< 1200 N/mm <sup>2</sup>	150-170	0,15-0,20	40-100	0,01-0,02	0,03-0,05	0,04-0,06
	1.14 Rapid steel	< 1300 N/mm <sup>2</sup>	140-160	0,12-0,18	40-100	0,01-0,02	0,03-0,05	0,04-0,06
	1.15 Cold work tool steel	< 1300 N/mm <sup>2</sup>	140-160	0,12-0,18	40-100	0,01-0,02	0,03-0,05	0,04-0,06
	1.16 Hot work tool steel	< 1300 N/mm <sup>2</sup>	140-160	0,12-0,18	40-100	0,01-0,02	0,03-0,05	0,04-0,06
<b>R</b>	2.1 Stainless steel, sulphured	< 850 N/mm <sup>2</sup>	180-200	0,20-0,25	50-150	0,03-0,04	0,03-0,04	0,05-0,12
	2.2 Stainless steel, ferritic	< 750 N/mm <sup>2</sup>	180-200	0,20-0,25	50-150	0,03-0,04	0,03-0,04	0,05-0,12
	2.3 Stainless steel, martensitic	< 900 N/mm <sup>2</sup>	160-180	0,15-0,20	50-150	0,03-0,04	0,03-0,04	0,05-0,12
	2.4 Stainless steel, ferritic/martensitic	< 1100 N/mm <sup>2</sup>	150-170	0,15-0,20	50-150	0,03-0,04	0,03-0,04	0,05-0,12
	2.5 Stainless steel, austenitic/ferritic	< 850 N/mm <sup>2</sup>	180-200	0,20-0,25	50-150	0,03-0,04	0,03-0,04	0,05-0,12
	2.6 Stainless steel, austenitic	< 750 N/mm <sup>2</sup>	180-200	0,20-0,25	50-150	0,03-0,04	0,03-0,04	0,05-0,12
	2.7 Heat-resisting steel	< 1100 N/mm <sup>2</sup>	150-170	0,15-0,20	50-150	0,03-0,04	0,03-0,04	0,05-0,12
<b>F</b>	3.1 Flake-graphite cast iron	100-350 N/mm <sup>2</sup>	200-220	0,20-0,25	100-200	0,03-0,07	0,03-0,07	0,04-0,08
	3.2 Flake-graphite cast iron	300-1000 N/mm <sup>2</sup>	200-220	0,20-0,25	100-200	0,03-0,07	0,03-0,07	0,04-0,08
	3.3 Spheroidal graphite cast iron	300-500 N/mm <sup>2</sup>	200-220	0,20-0,25	100-200	0,03-0,07	0,03-0,07	0,04-0,08
	3.4 Spheroidal graphite cast iron	550-800 N/mm <sup>2</sup>	200-220	0,20-0,25	100-200	0,03-0,07	0,03-0,07	0,04-0,08
	3.5 Whiteheart malleable cast iron	350-450 N/mm <sup>2</sup>	200-220	0,20-0,25	100-200	0,03-0,07	0,03-0,07	0,04-0,08
	3.6 Whiteheart malleable cast iron	500-650 N/mm <sup>2</sup>	200-220	0,20-0,25	100-200	0,03-0,07	0,03-0,07	0,04-0,08
	3.7 Blackheart malleable cast iron	350-450 N/mm <sup>2</sup>	200-220	0,20-0,25	100-200	0,03-0,07	0,03-0,07	0,04-0,08
	3.8 Blackheart malleable cast iron	500-700 N/mm <sup>2</sup>	200-220	0,20-0,25	100-200	0,03-0,07	0,03-0,07	0,04-0,08
<b>N</b>	4.1 Aluminium (unalloyed, low alloyed)	< 350 N/mm <sup>2</sup>	350-400	0,20-0,25	250-500	0,05-0,07	0,05-0,07	0,06-0,12
	4.2 Aluminium alloys < 0,5% Si	< 500 N/mm <sup>2</sup>	300-400	0,20-0,25	250-500	0,05-0,07	0,05-0,07	0,06-0,12
	4.3 Aluminium alloys 0,5-10% Si	< 400 N/mm <sup>2</sup>			250-500	0,05-0,07	0,05-0,07	0,06-0,12
	4.4 Aluminium alloys 10-15% Si	< 400 N/mm <sup>2</sup>			250-500	0,05-0,07	0,05-0,07	0,06-0,12
	4.5 Aluminium alloys > 15% Si	< 400 N/mm <sup>2</sup>			180-250	0,05-0,07	0,05-0,07	0,06-0,12
	4.6 Cooper (unalloyed, low alloyed)	< 350 N/mm <sup>2</sup>	350-400	0,20-0,25	250-300	0,05-0,07	0,05-0,07	0,06-0,08
	4.7 Cooper wrought alloys	< 700 N/mm <sup>2</sup>						
	4.8 Cooper special alloys	< 200 HB						
	4.9 Cooper special alloys	< 300 HB						
	4.10 Cooper special alloys	> 300 HB						
	4.11 Brass, short-chipping, Bronze, Red brass	< 600 N/mm <sup>2</sup>	200-300	0,20,0,25	250-300	0,05-0,07	0,05-0,07	0,06-0,08
	4.12 Brass, long-chipping	< 600 N/mm <sup>2</sup>						
	4.13 Thermoplastic				350-450	0,08-0,1	0,08-0,1	0,1-0,12
	4.14 Thermosetting plastic				300-400	0,08-0,1	0,08-0,1	0,1-0,12
	4.15 Fibre-reinforced plastics				180-200	0,02-0,04	0,02-0,04	0,03-0,04
	4.16 Magnesium and magnesium alloys	< 850 N/mm <sup>2</sup>						
	4.17 Graphite							
	4.18 Wolfram and wolfram alloys							
	4.19 Molybdenum and molybdenum alloys							
<b>S</b>	5.1 Pure nickel							
	5.2 Nickel alloys		180-200	0,20-0,25				
	5.3 Nickel alloys	< 850 N/mm <sup>2</sup>	180-200	0,20-0,25	60-80	0,02-0,04	0,02-0,04	0,03-0,04
	5.4 Nickel-chrome alloys							
	5.5 Nickel- and cobalt alloys	< 1300 N/mm <sup>2</sup>						
	5.6 Nickel- and cobalt alloys	< 1300 N/mm <sup>2</sup>						
	5.7 High temperature alloys	< 1300 N/mm <sup>2</sup>						
	5.8 Nickel-cobalt-(chrome-) alloys	< 1400 N/mm <sup>2</sup>						
	5.9 Pure Titanium	< 900 N/mm <sup>2</sup>						
	5.10 Titanium alloys	< 700 N/mm <sup>2</sup>	140-160	0,15-0,20				
	5.11 Titanium alloys	< 1200 N/mm <sup>2</sup>	120-140	0,12-0,18	50-80	0,01-0,03	0,01-0,03	0,01-0,03
<b>H</b>	6.1 Hardened steel	< 45 HRC	80-100	0,04-0,06	40-60		0,03-0,05	0,03-0,05
	6.2	46-55 HRC	70-90	0,04-0,06	40-50		0,03-0,05	0,03-0,05
	6.3	56-60 HRC	60-80	0,03-0,05	30-40		0,02-0,04	0,02-0,04
	6.4	61-65 HRC	50-70	0,03-0,05				
	6.5	65-70 HRC	40-60	0,02-0,04				

\* The indicated feed values apply only with circular bringing in loop. During linear bringing in movement the feed motion amounts to max. 30%

	System 14,5-26 + TrioCUT			PolyMILL 3/6 Cutting Edges		TriMILL	
	TINAMATIC	12, 14,5, 15, 17, 20, 25	21, 26	TINAMATIC		TINAMATIC	
	Vc (m/min.)	fz mm	fz mm	Vc (m/min.)	fz mm	Vc (m/min.)	fz mm
1.1	180-260	0,1-0,3	0,05-0,3	150-200	0,05-0,25	120-180	0,05-0,12
1.2	180-260	0,1-0,3	0,05-0,3	150-200	0,05-0,25	120-180	0,05-0,12
1.3	180-260	0,1-0,3	0,05-0,3	100-150	0,05-0,25	120-180	0,05-0,12
1.4	180-220	0,1-0,3	0,05-0,3	100-150	0,05-0,25	100-120	0,05-0,12
1.5	180-260	0,1-0,3	0,05-0,3	150-200	0,05-0,25	120-180	0,05-0,12
1.6	180-220	0,1-0,3	0,05-0,3	100-150	0,05-0,25	100-120	0,05-0,12
1.7	180-260	0,1-0,3	0,05-0,3	100	0,05-0,25	120-180	0,05-0,12
1.8	100-150	0,1-0,2	0,05-0,2	100	0,05-0,25	80-100	0,05-0,12
1.9	180-260	0,1-0,3	0,05-0,3			100-120	0,05-0,12
1.10	100-150	0,1-0,2	0,05-0,2	120	0,05-0,25	100-120	0,05-0,12
1.11	100-150	0,1-0,2	0,05-0,2	100	0,05-0,25	80-100	0,05-0,12
1.12	100-150	0,1-0,2	0,05-0,2			80-100	0,05-0,12
1.13	100-150	0,1-0,2	0,05-0,2	100	0,05-0,25	80-100	0,05-0,12
1.14	100-120	0,1-0,2	0,05-0,2	100	0,05-0,25	80-100	0,05-0,12
1.15	100-150	0,1-0,2	0,05-0,2	100	0,05-0,25	80-100	0,05-0,12
1.16	100-150	0,1-0,2	0,05-0,2	100	0,05-0,25	80-100	0,05-0,12
2.1						120-150	0,05-0,12
2.2						120-150	0,05-0,12
2.3	130-180	0,1-0,3	0,05-0,3	120	0,05-0,25	100-120	0,05-0,12
2.4				120	0,05-0,25	100-120	0,05-0,12
2.5				120	0,05-0,25	120-180	0,05-0,12
2.6	80-100	0,1-0,2	0,05-0,15	180	0,05-0,25	120-180	0,05-0,12
2.7						80-100	0,05-0,12
3.1	130-200	0,1-0,3	0,05-0,3	180	0,05-0,25	120-180	0,05-0,12
3.2	130-200	0,1-0,3	0,05-0,3	120	0,05-0,25	120-180	0,05-0,12
3.3	130-200	0,1-0,3	0,05-0,3	180	0,05-0,25	120-180	0,05-0,12
3.4	130-200	0,1-0,3	0,05-0,3	180	0,05-0,25	120-150	0,05-0,12
3.5	130-200	0,1-0,3	0,05-0,3	180	0,05-0,25	120-180	0,05-0,12
3.6	130-200	0,1-0,3	0,05-0,3	120	0,05-0,25	120-180	0,05-0,12
3.7	130-200	0,1-0,3	0,05-0,3	180	0,05-0,25	120-180	0,05-0,12
3.8	130-200	0,1-0,3	0,05-0,3	120	0,05-0,25	120-180	0,05-0,12
4.1	400-600	0,1-0,3	0,05-0,3	160-400	0,05-0,12		0,05-0,25
4.2	400-600	0,1-0,3	0,05-0,3	160-400	0,05-0,12		0,05-0,25
4.3							
4.4							
4.5							
4.6				500	0,15-0,4	300-500	0,05-0,25
4.7							
4.8							
4.9							
4.10							
4.11				400	0,15-0,4	200-300	0,05-0,25
4.12							
4.13				500	0,15-0,4	300-500	0,05-0,25
4.14				500	0,15-0,4	300-500	0,05-0,25
4.15							
4.16							
4.17				500	0,15-0,4	300-500	0,05-0,25
4.18							
4.19							
5.1							
5.2				120	0,05-0,25	80-120	0,05-0,12
5.3				120	0,05-0,25	80-120	0,05-0,12
5.4							
5.5							
5.6							
5.7							
5.8							
5.9							
5.10				80	0,01-0,08	70-100	0,01-0,05
5.11				60	0,01-0,08	60-90	0,01-0,05
6.1						80-100	0,03-0,1
6.2				80	0,03-0,15	80	0,03-0,1
6.3							
6.4							
6.5							